

# BALLPROGRAMM KLOSTERDANCE 2012 (JOCHEN KLEPPER HAUS)

## The beginning

**BACK TO BACK** T Glasspool Itch to Dance J32

DT<sub>R</sub> ↗ DT<sub>R</sub> 1½

① ② D<sub>RSH</sub> ③ ② D<sub>LSh</sub> ③

① ② D<sub>RSH</sub> ③ ② D<sub>LSh</sub> ③

T<sub>R</sub> (to ① ② ③) S (to ① ② ③)

**WEST'S HORNPIPE** RSCDS 1965 H32

① S ② ③ ④ ①

① S ② ③ ④

**FIRESIDE STRATHSPEY** D Haynes Carnforth Coll 3 S32

TOURNEE RA LA T<sub>L</sub> 1½ chase ⑥

1L 2 1M 3 1 2 3 4th cmr 1 3rd cmr

T<sub>L</sub> at end of reel

**RED NOSE JIG** J40

Square Set 2 4 all ladies men ALL ALL prom. hold Repeat 3 times from new places

① ③ ③ ① ① ③ ③ ①

R 4 arch, 2 arch

R ③ ¼ chase anticlockwise

**CABERFEI** 18th C R32

RA LA ② ① ③ S ① ③ S ① ③ S ① ③ T<sub>R</sub>

**MISS GIBSON'S STRATHSPEY** RSCDS L S32

ST<sub>B</sub> ④ KNOT Turn corner & partner L + RA ① ① RA LA ① ① LA ② ③ ② ③

## The Swinging Kilts Scottish & Irish Folk Dancing in Duisburg



April 21th, 2012  
At 7:00 p.m.

**HIGHLAND FAIR** Gr 6 J32

T<sub>R</sub> T<sub>L</sub> 1 2 1 2 1's leading 2's leading (to ② ①) ② ① RL



**AUTUMN IN APPIN** XXXI 5 S32

2nd chord 3's & 4's cross to opposite sides

2 3 - 2 3 - 1 4 - T<sub>R</sub> ¾ RA T<sub>R</sub> ½

ALL PROM clockwise

1 4 2 3 (to ② ③ ④ ①) S ⑧ All spiral out of centre of circle (to ② ④ ① ③) ② ④ ① ③

**MAUREEN'S REEL** D Haynes Carnforth Coll 1 R32

X<sub>R</sub> ↗ X<sub>L</sub> (to ② ③ ① ②) S T<sub>R</sub> T<sub>R</sub> S T<sub>R</sub> (to ② ③ ① ②) CT Crown Triangles ⑥

**POLHARROW BURN (5 couples)** Foss R32

- 1 3 - 2 ① ④ ③ - 1 3 - 2 ① ④ ③ - 5 -

X ↗ T<sub>R</sub> T<sub>L</sub> X<sub>R</sub> ② ④ X<sub>R</sub> ⑤ ④ ⑤

⑤ ① ④ ④ ③ ② ⑤ ① ② ⑤ ③ ② ④ ① ② ⑤ ③ ④ - 1 3 - T<sub>L</sub> ↗

Time for quatsching

**OKTOBER IN RECHBERG** Zobel/Johnstone S32

Between Lady under 2 & 3 Man's arm (to ② ① ③) 1 in prom. hold 1 in prom. hold (to ② ① ③) circulating allemande ① ① ① T<sub>R</sub> ½ (to ② ③ ① ②) ① ③ ① ③ ① ③

# BALLPROGRAMM KLOSTERDANCE 2012 (JOCHEN KLEPPER HAUS)

## Mairi's Wedding (zum Singen in der Pause)

Step we gaily on we go, heel for heel toe for toe  
Arm in arm and row in row, all for Mairi's wedding

Over hillways up and down, myrtle green and bracken brown  
Past the sheiling through the town, all for sake of Mairi

Red her cheeks as rowans are, brighter eyes than any star  
Fairest o' them all by far, is my darling Mairi

Plenty herring, plenty meal, plenty peat to fill her creel  
Plenty bonny bairns as weel, that's the toast for Mairi

Brighter cheeks as rowans are, brighter eye as any star  
The fairest of them all by far is our darling Mairi

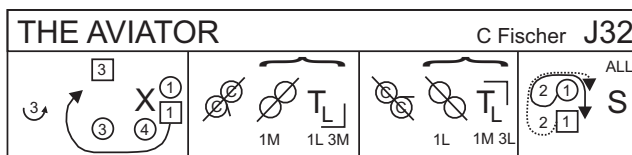
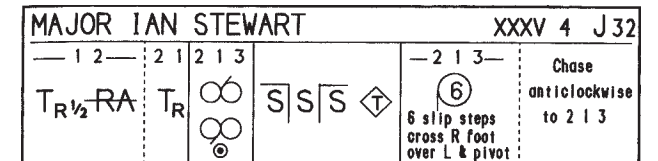
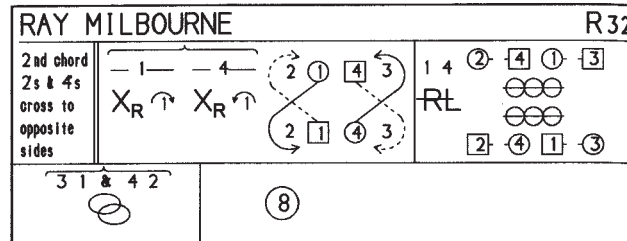
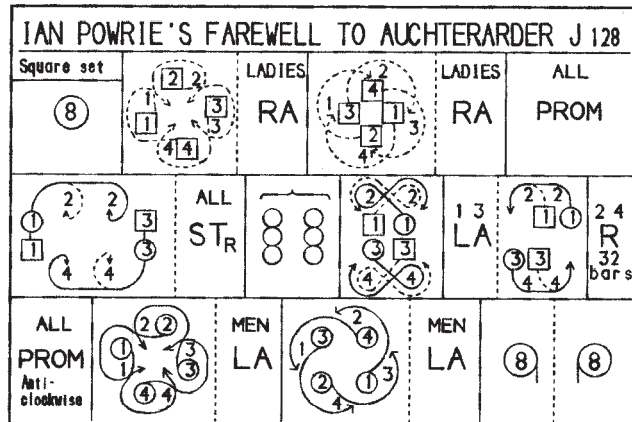
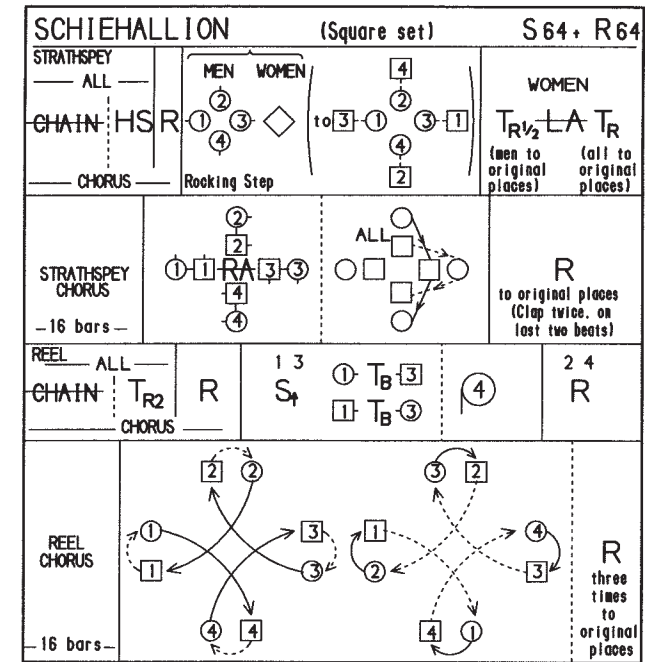
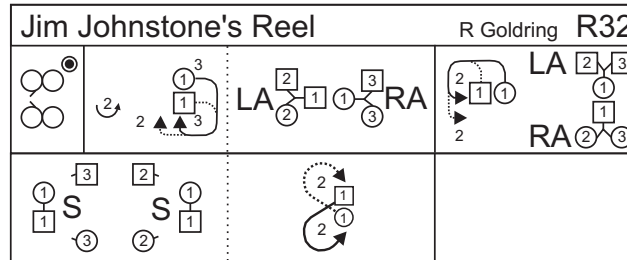
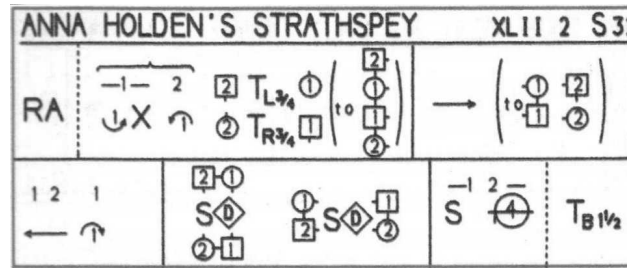

Seit 1977 kann man im Raum Duisburg Schottisch Tanzen. Was damals mit einer Handvoll Tänzer begann, ist inzwischen zu einer großen Familie mit über 100 Tänzern herangewachsen. Neben Scottish Country Dancing kann man sich bei uns auch mit Irish Ceilí oder Irish Step Dancing die Langeweile vertreiben.

Ruft an: 0203/4106457 oder besucht uns unter [www.swinging-kilts.de](http://www.swinging-kilts.de)